

Energy Conservation

Star Jet Thermocompressors JC

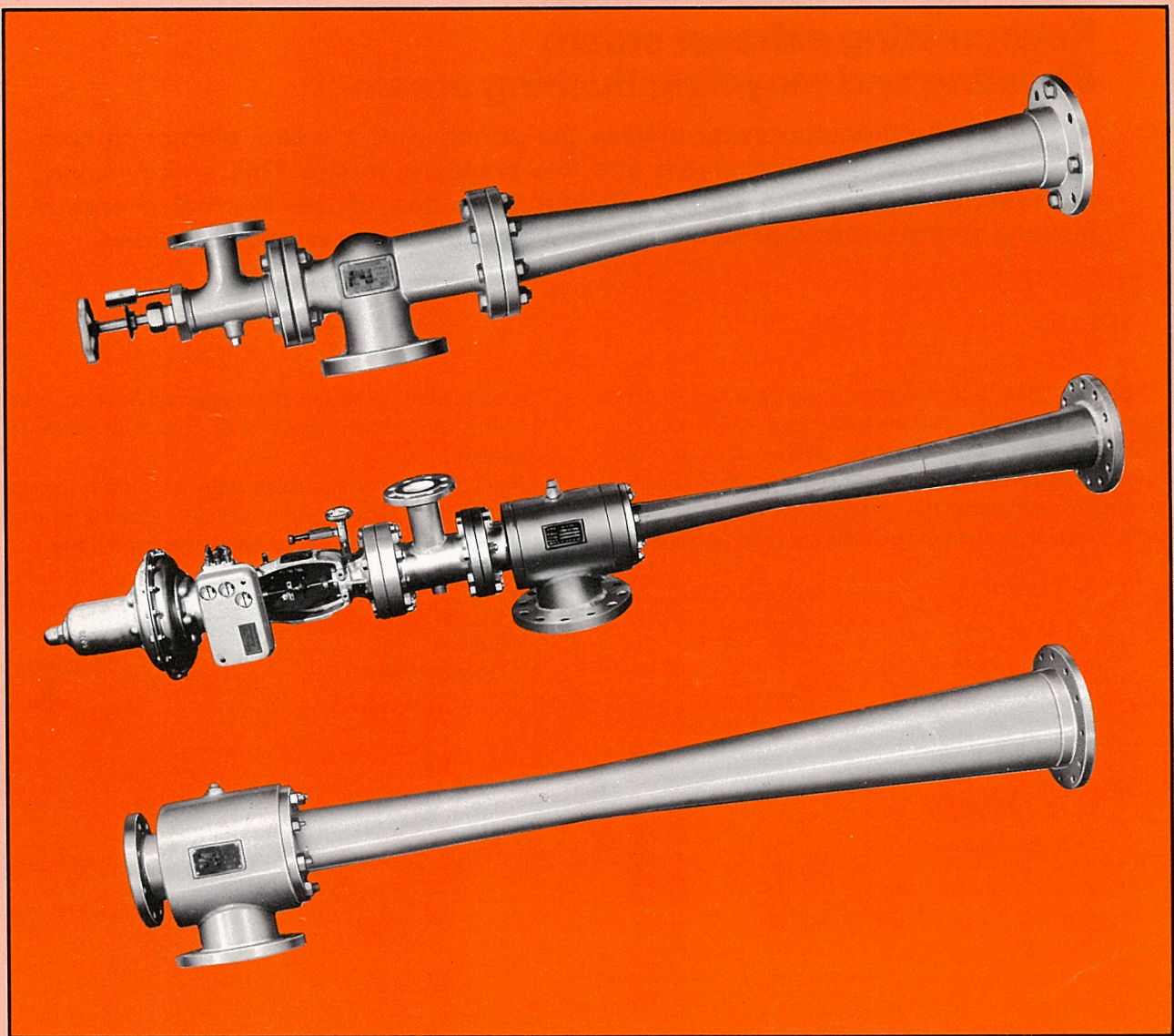

HOKUTO MFG. CO., LTD.

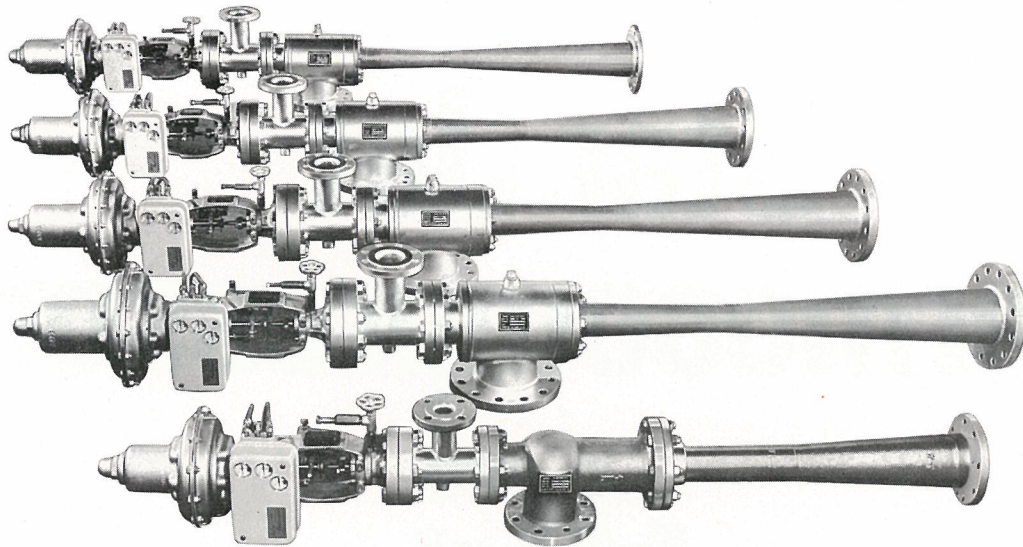

Boosting low-pressure steam
Recirculating exhaust steam
Boosting and recycling flushing steam

A Star jet thermocompressor utilizes the principle of a steam ejector to compress and boost flushing steam and low-pressure steam. This energy-saving equipment salvages and allows efficient utilization of the thermal energy in flushing steam and low-pressure steam, which otherwise would be wasted.

CONSTRUCTION

A Star jet thermocompressor is constructed of three basic parts: a body, a steam nozzle and a diffuser. The high-velocity jet of steam emitted by the nozzle creates a suction in the body which draws the low-pressure steam into the chamber where it is mixed with the motive steam. The diffuser then converts the

kinetic energy of the high-velocity flow to pressure energy so that the desired discharge pressure is obtained.

A jet thermocompressor with its built-in regulating mechanism allows highly efficient control in accordance with changes in the discharge conditions.

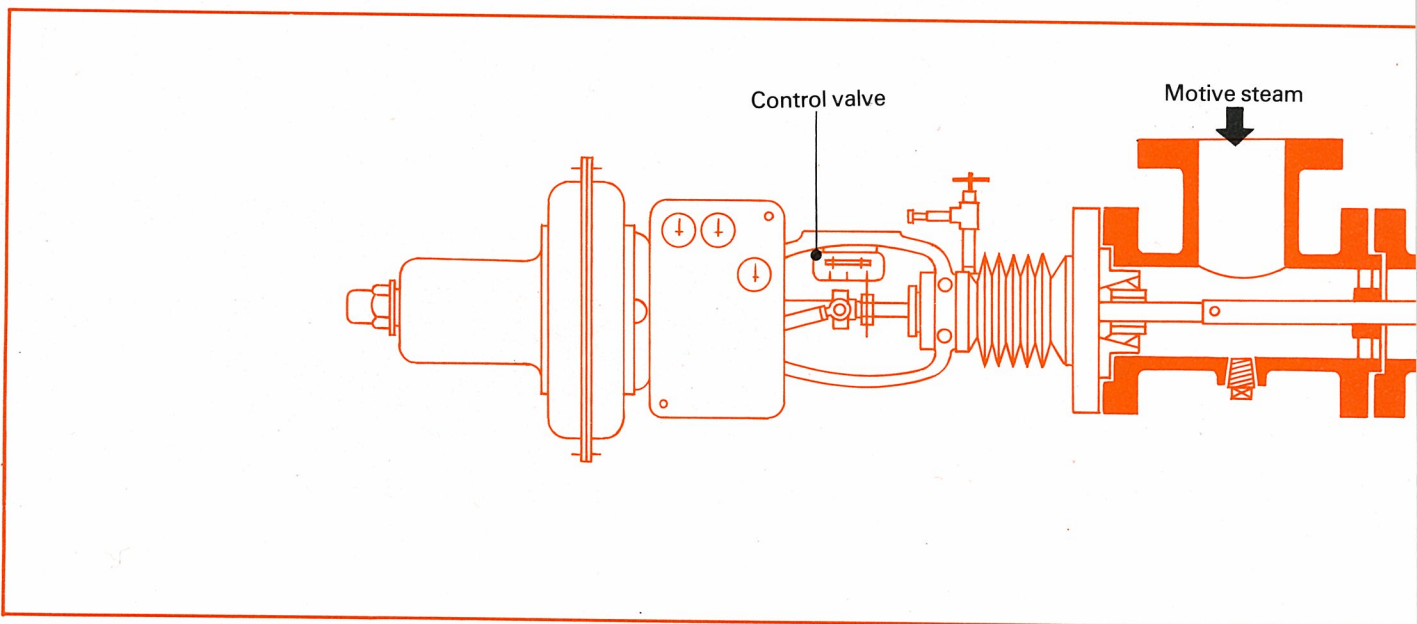

ADVANTAGES

Star jet thermocompressors feature a simple construction and are easy to operate. Many years of field-proven experience and technology go into the design of each Star product.

One of the strong points of Star jet thermocompressors is their extraordinarily simple construction. There are no parts that might break and require immediate replacement. Star jet thermocompressors can with-

stand long years of service without failure, thus eliminating bothersome repairs and the need for constant adjustment. Since Star jet thermocompressors are virtually maintenance free, they can be used in remote locations. They can also be installed in places where flammables are present.

Two other advantages of Star jet thermocompressors are their low original price and low maintenance cost.

APPLICATIONS

• Steam recirculation

Jet thermocompressors are employed to recirculate the exhaust steam of heating equipment by mixing it with the motive steam.

By salvaging and recycling the heat energy in exhaust steam, which otherwise would be wasted, jet thermocompressors assure efficient energy utilization.

• Boosting low-pressure steam; recycling flushing steam

Jet thermocompressors are used to mix and boost low-pressure steam and flushing steam with motive steam for supply to manufacturing processes. Thus they enable the thermal energy in low-pressure steam and flushing steam to be recycled instead of being lost.

ENERGY SAVINGS

Oil prices continue to climb annually without any sign of slowing down. An investment in energy-saving equipment like Star jet thermocompressors can be recovered in no time. The excellent energy savings that can be expected will lead to higher corporate profits.

The superior suction ratio of Star jet thermocompressors is best demonstrated by their energy-saving performance.

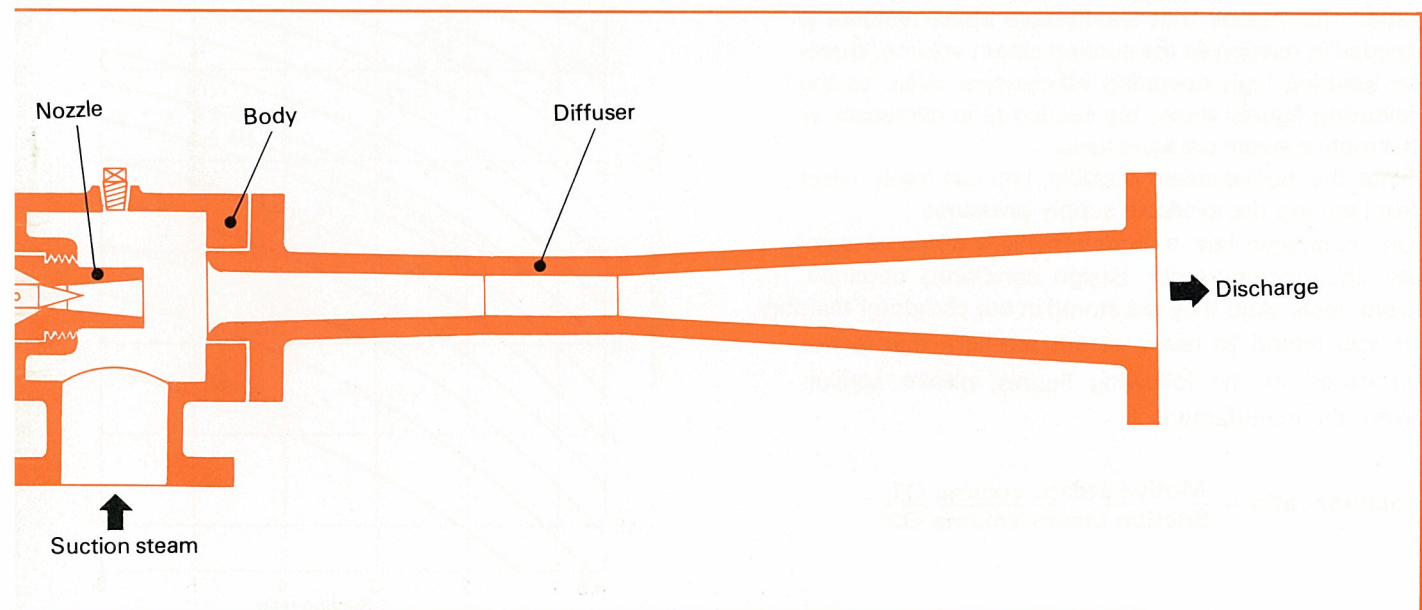
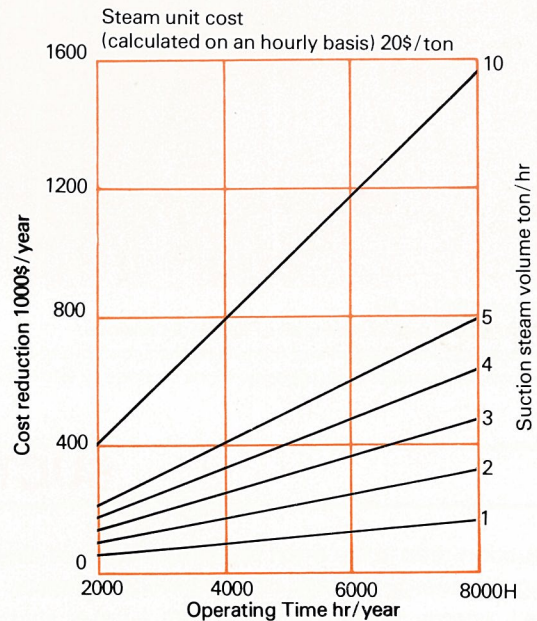

SIZE • CONNECTIONS • MATERIALS

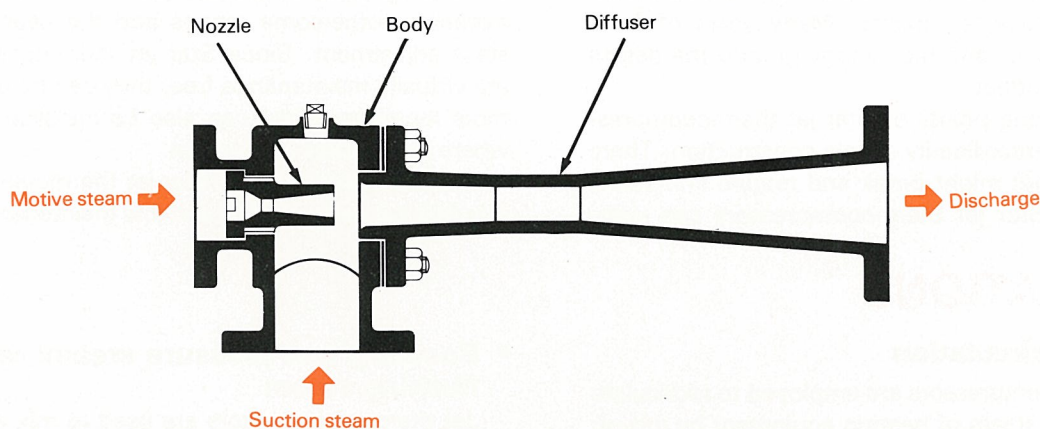

Table 1.

SIZE NO.	*Connection in inches			Standard Materials				
	Suction	Discharge	Motive steam	Body		Nozzle	Diffuser	
8JC	2 ^B	2 ^B	3/4 ^B ~ 1 1/4 ^B	Cast Steel	Cast stainless	Stainless	Steel	Stainless
10JC	2 1/2	2 1/2	1 ~ 1 1/2	"	"	"	"	"
12JC	3	3	1 ~ 2	"	"	"	"	"
16JC	4	4	1 1/2 ~ 2 1/2	"	"	"	"	"
20JC	5	5	1 1/2 ~ 3	"	Stainless	"	"	"
24JC	6	6	2 ~ 4	"	"	"	"	"
32JC	8	8	2 ~ 5	Steel	"	"	"	"
40JC	10	10	3 ~ 6	"	"	"	"	"
48JC	12	12	4 ~ 8	"	"	"	"	"

*Flange are ANSI or JIS

*The table shows typical examples of flange dimensions.

All products can be designed and manufactured according to the required specifications.

*Please use the manufacturing specifications on page 12 when making estimates and ordering.

SUCTION RATIO

The suction ratio is the most important factor in determining the energy savings of a thermocompressor. In general, energy savings increase with a lower suction ratio. This means that less motive steam volume is needed in relation to the suction steam volume, thereby assuring high operating efficiencies. Also, as the following figures show, the suction ratio decreases as the motive steam pressure rises.

Since the motive steam is stable, you can freely select from among the available supply pressures.

Our company has a comprehensive range of data on thermocompressor design conditions obtained from tests. And they are stored in our computer memory.

If you intend to use a steam pressure that is not indicated in the following figures, please consult with the manufacturer.

$$\text{Suction ratio} = \frac{\text{Motive steam volume } Q_1}{\text{Suction steam volume } Q_2}$$

Figure 1. Motive steam pressure 5 kg/cm²G

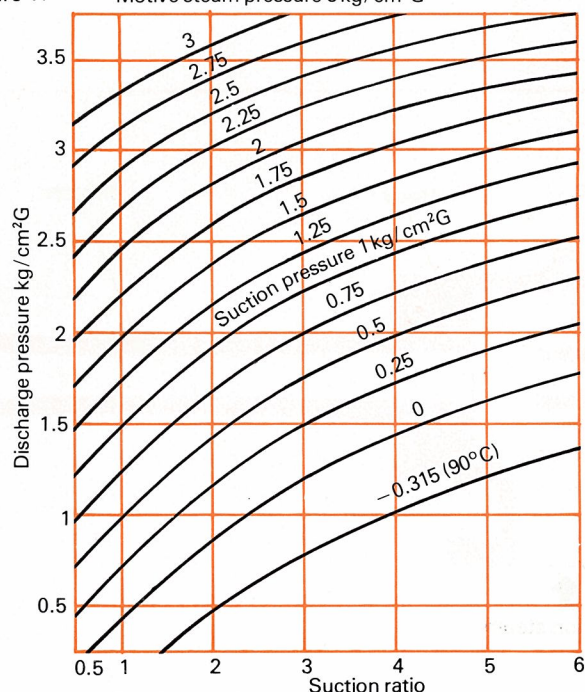

Figure 2.

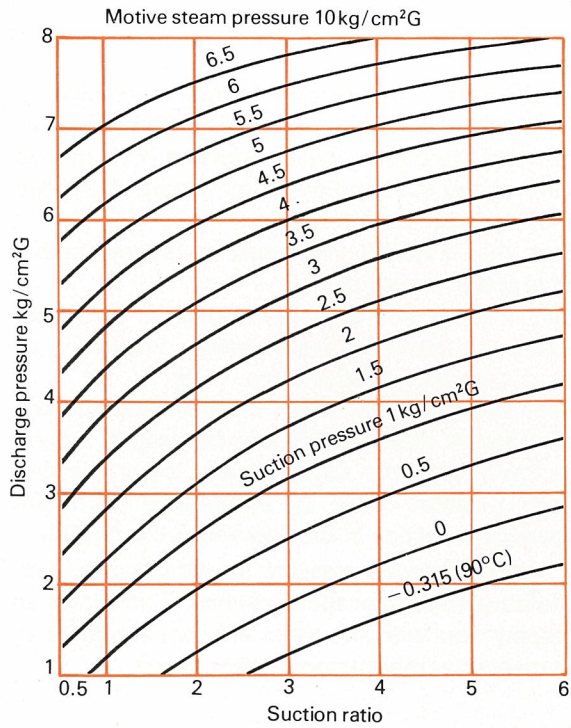

Figure 3.

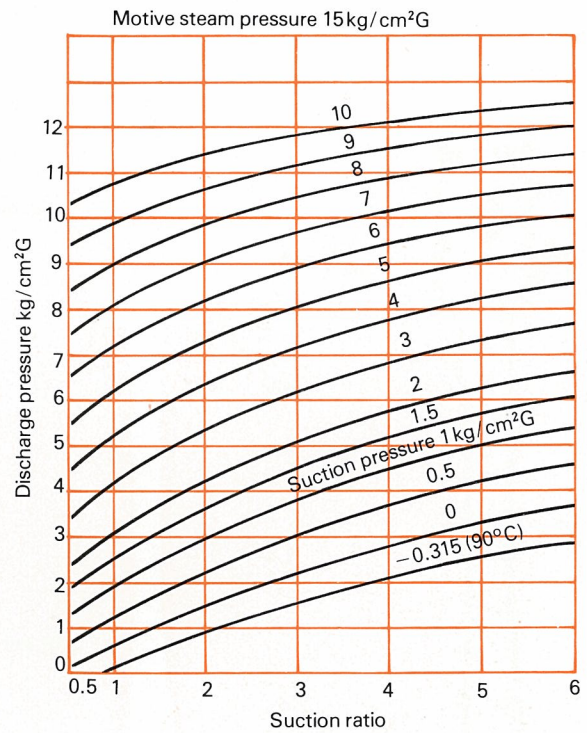

Figure 4.

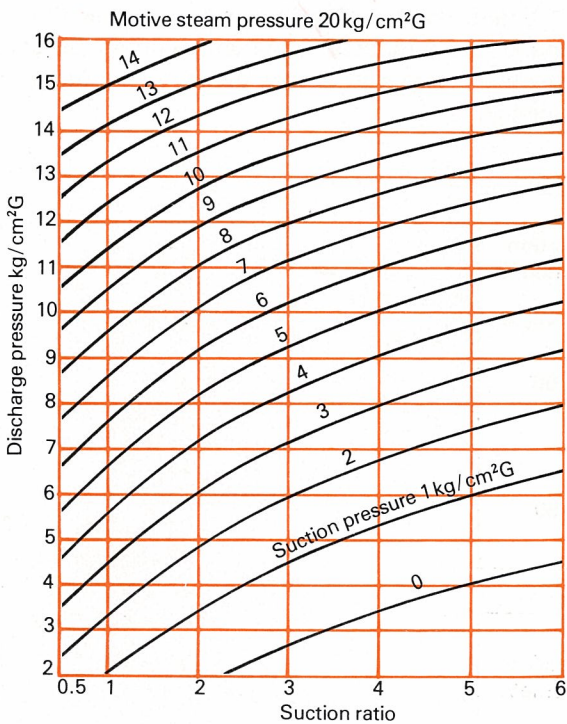
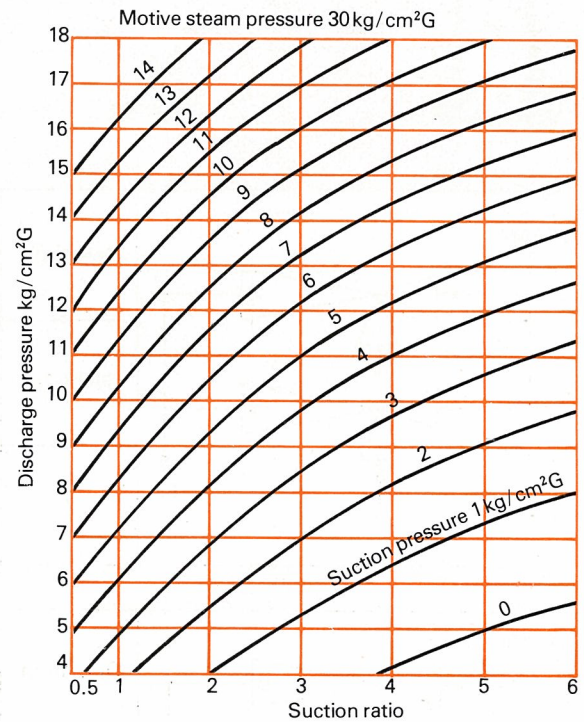

Figure 5.



• **Sections not recorded on the figures.**

1. When the suction ratio is off Figs. 2 through 5.
2. When the suction steam pressure is below $-0.315 \text{ kg/cm}^2 (90^\circ\text{C})$. With the Star Jet compressor, even when there is a small amount of flushing steam and low-pressure steam, recovery is large and energy is effectively saved.
3. Super heat steam.

JC-Type Fixed-Nozzle Thermocompressor

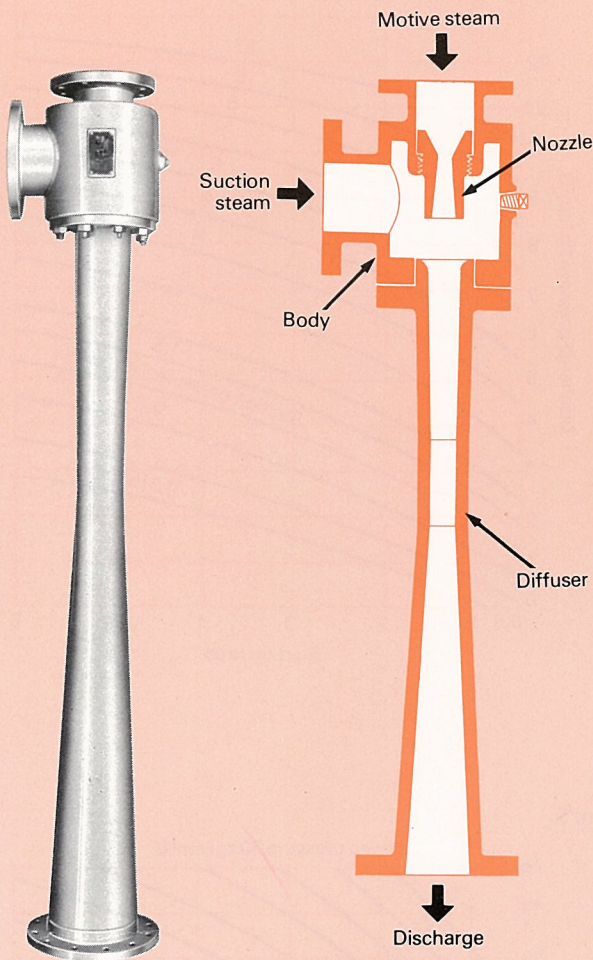

- The JC-type fixed-nozzle thermocompressor is used when the suction volume (Q_2) is fixed or varies and the motive steam pressure (P_1), motive steam volume (Q_1) and discharge pressure (P_3) are at their constant design values. Select the pressure you need to supply stable motive steam pressure.
- When flushing steam and low-pressure steam are intaken, the required motive steam volume is as shown in the suction ratio (Figs. 1 ~ 5).
- When, because of changes in specifications, the motive steam pressure (P_1) is to be used at a pressure lower than the design value, lower the discharge pressure (P_3) in accordance with the amount of reduction in the operating volume (Q_4).
- JC-Type thermocompressors are all designed and manufactured to user specifications. This allows us to supply you with the most efficient products to best meet your thermocompressor needs.

Parallel Use of JC-Type Thermocompressors

The installation of several JC-type thermocompressors allows optimum control of steam volume under the condition that the number of such thermocompressors is determined in terms of steam generation volume and frequency.

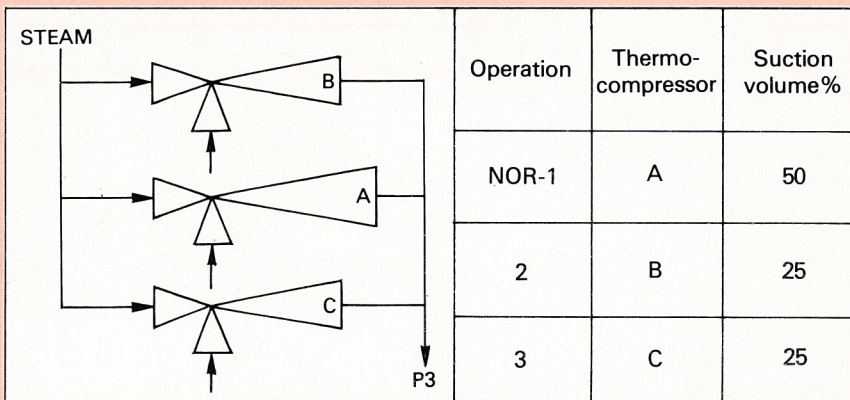
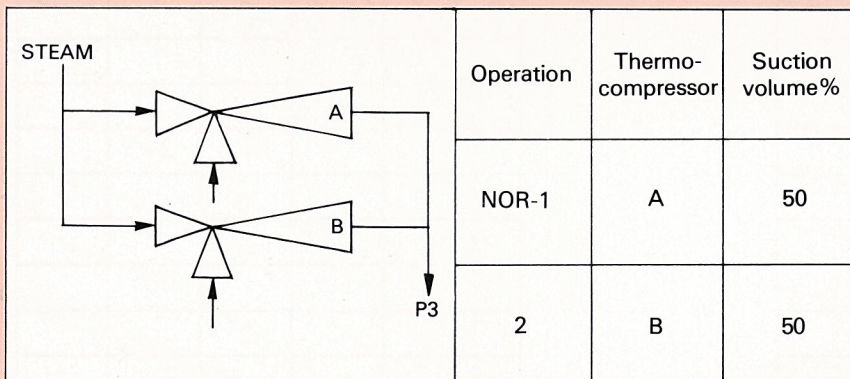

JC-MO Type Manual Control Thermocompressor

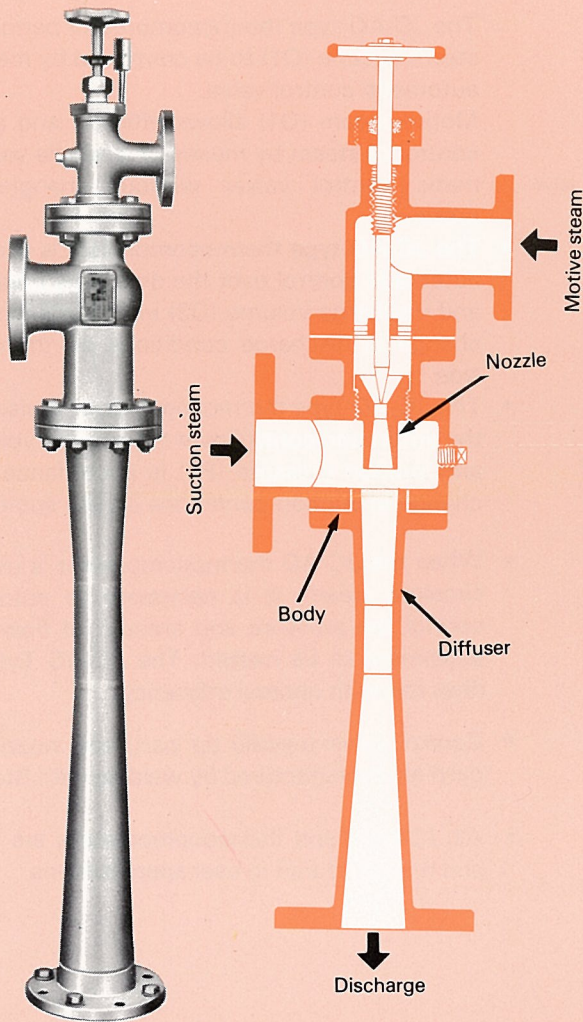

- The JC-MO Type manual control thermocompressor shows excellent results when used in situations where there are changes in operating conditions, but the suction volume is predictable and more elasticity is desired for the volume of motive steam.
- The JC-MO Type thermocompressor has the same operating range as the JC-AO Type. The suction ratio in the design values of Fig. 6 is the same as the suction rate in Fig. 2.
- The needle valve (tip part) and nozzle (throat part) are manufactured by welding with Stellite.
- Steam can not be completely shut off using the needle valve. When it is necessary to shut off motive steam completely, use the separately supplied steam valve (shut-off valve).
- The JC-MO Type thermocompressors are all designed and manufactured to user specifications.

JC-MO Type Thermocompressor Performance Curve (Example)

Fig. 6.

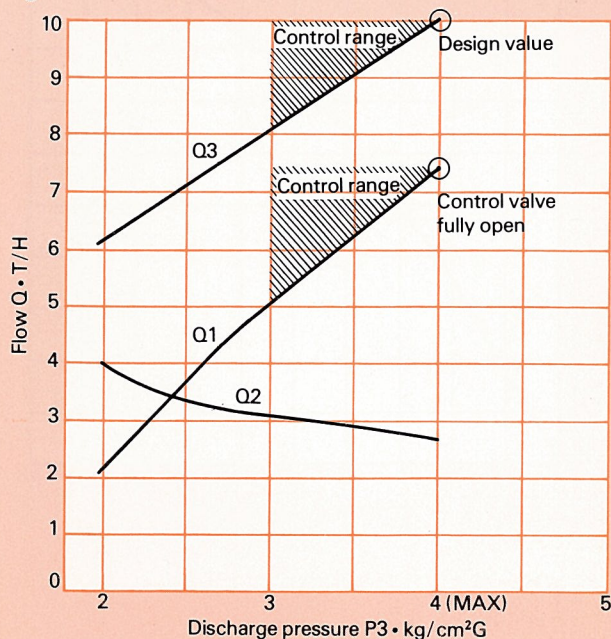

• Design values

P1 = 10 kg/cm ² G	Q1 = 7.2T/H	
P2 = 2 kg/cm ² G	Q2 = 2.8T/H	Q1/Q2 = 2.6
P3 = 4 kg/cm ² G	Q3 = 10T/H	

The control range expresses changes in the amount of steam when discharge pressure is kept constant at P3 = 3 kg/cm²G.

• Control Range

Q1	5~7.2T/H
Q2	3~2.8T/H
Q3	8~10T/H

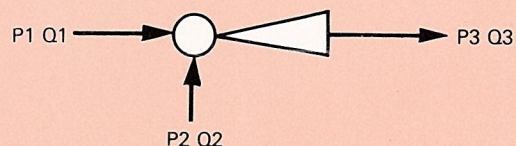

JC-AO Type Automatically Controlled Thermocompressor

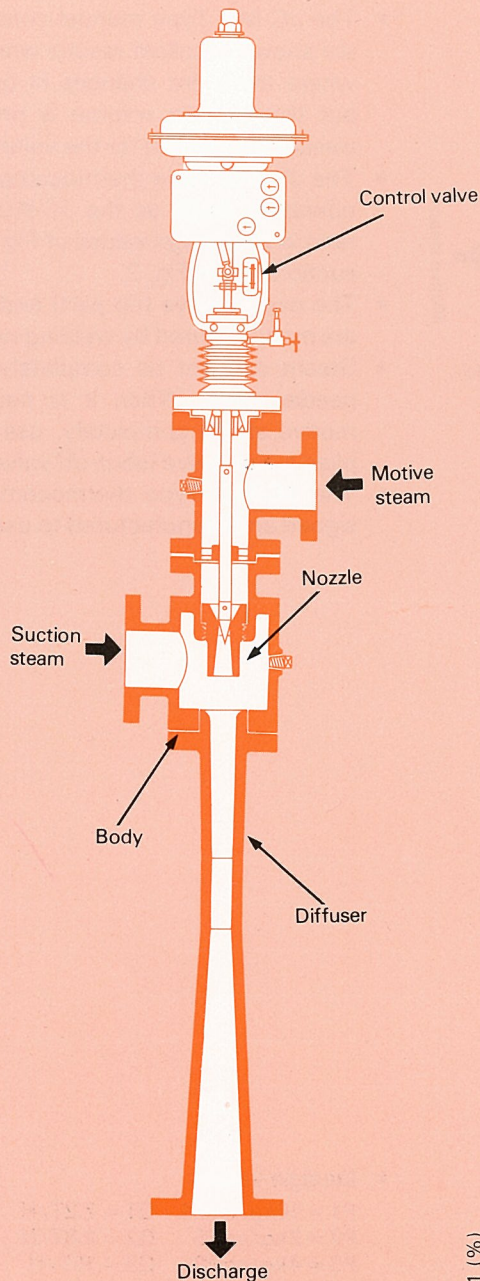
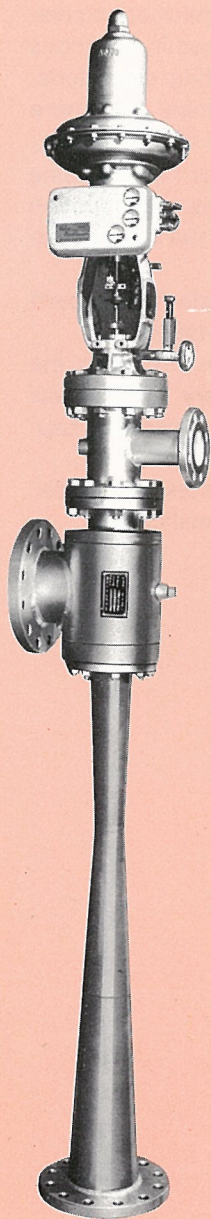

The JC-AO-type thermocompressor permits motive steam volume (Q1) to be controlled by means of an automatic control valve.

Motive steam (Q1) allows efficient and automatic control of steam by means of a needle valve (automatic control valve) without changing steam pressure.

- The JC-AO-type thermocompressor is used for the automatic control over the discharge pressure (P3) and discharge volume (Q3) in accordance with the change in discharge conditions on the discharge side.
- The JC-AO-type thermocompressor is also used for the automatic control over the suction volume (Q2) and suction pressure (P2) in accordance with the change in suction conditions on the suction side.
- When the JC-AO thermocompressor is used to recirculate steam, it is necessary to automatically control the pressure and amount of flow into the equipment to be heated. The JC-AO Type model does this with optimal efficiency.
- Control valve (needle tip part) and nozzle (throat part) are manufactured by welding with Stellite.
- All JC-AO Type thermocompressors are designed and manufactured to user specifications.

CONTROL VALVE CHARACTERISTIC CURVE

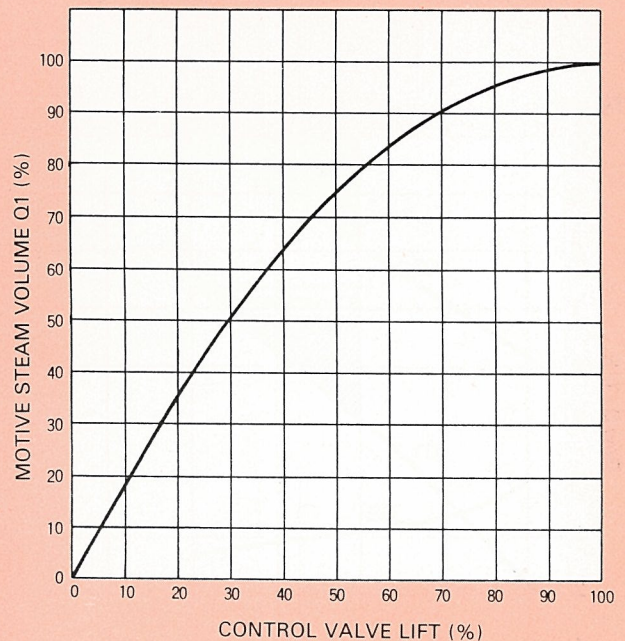

JC-AO Type Thermocompressor Performance Curve (Example)

Design values

$P_1 = 20 \text{ kg/cm}^2\text{G}$ $Q_1 = 6 \text{ T/H}$
 $P_2 = 2 \text{ kg/cm}^2\text{G}$ $Q_2 = 4 \text{ T/H}$ $Q_1/Q_2 = 1.5$
 $P_3 = 4 \text{ kg/cm}^2\text{G}$ $Q_3 = 10 \text{ T/H}$

- When determining pressure conditions P_1 , P_2 and P_3 , the suction ratio Q_1/Q_2 is computed using the performance data (Suction ratio Figs. 1 ~ 5).
- When one of the flow volume conditions Q_1 , Q_2 and Q_3 points in a particular direction, the other two directions are computed from Figs. 1 ~ 5.
- Control example of Q_1 and Q_3 when P_3 is constant at $3 \text{ kg/cm}^2\text{G}$. (Refer to Figs. 7 and 8).

Table 2.

P_2 kg/cm ² G	Q_1 T/H		Q_3 T/H
	min ~ max	Control valve fully open	
3.0	2.5 ~ 6	↑	8 ~ 11.3
2.5	3.2 ~ 6	Control valve fully open	8 ~ 10.6
Design value 2.0	3.8 ~ 6	open	8 ~ 10.0
1.5	4.5 ~ 6	↓	8 ~ 9.3
1.0	5.2 ~ 6		8 ~ 8.6

- Q_2 and P_3 increase and decrease in proportion to P_2 . (Refer to Fig. 8.)

Table 3.

P_2 kg/cm ² G	P_3 kg/cm ² G min ~ max	Q_2 Control valve fully open
3.0	3.0 ~ 4.65	5.3
2.5	2.5 ~ 4.30	4.6
Design value 2.0	2.0 ~ 4.00	4.0
1.5	1.5 ~ 3.65	3.3
1.0	1.0 ~ 3.30	2.6

- What will happen if it is used at $18 \text{ kg/cm}^2\text{G}$, below its design value of $20 \text{ kg/cm}^2\text{G}$?
 - The motive volume Q_1 will decrease when the control valve is fully open.

$$Q_1 = \frac{19 \text{ ata}}{20 \text{ ata}} \times 6 \text{ T/H} = 5.43 \text{ T/H}$$

- When the control valve is fully open P_3 will fall.

When $Q_1 = 5.43 \text{ T/H}$ and $P_2 = 2 \text{ kg/cm}^2\text{G}$, P_3 will fall from $4 \text{ kg/cm}^2\text{G}$ to $3.7 \text{ kg/cm}^2\text{G}$.

- Q_2 will decrease slightly.

Fig. 7.

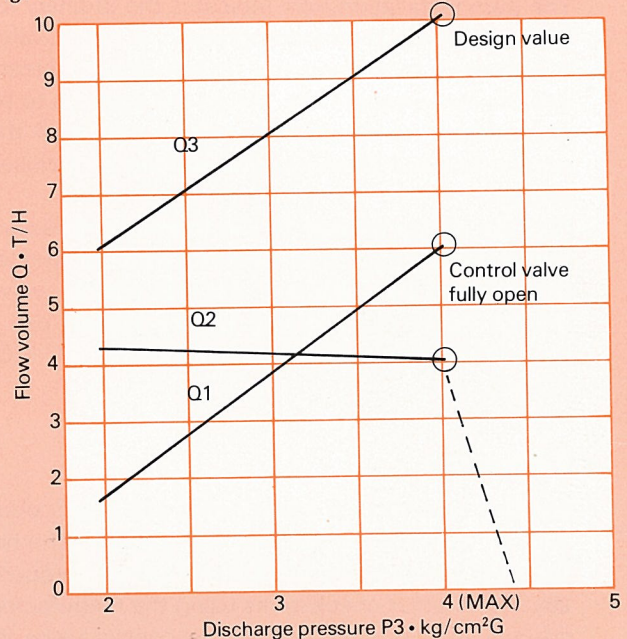
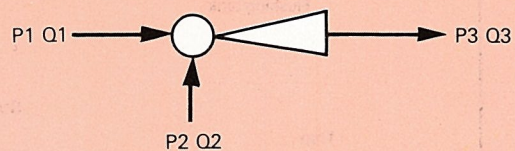
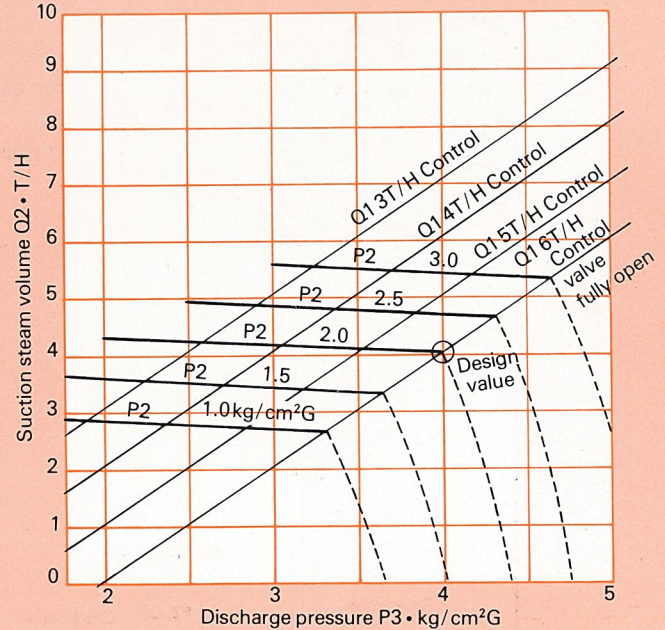

Fig. 8.



Installation and Operation

• Installation:

The term installation here indicates the ordinary installation of the thermocompressor. A check valve is necessary to prevent the reverse flow of steam into the low-pressure line. When the steam is to be recirculated, no check valve will be needed if the suction line and discharge line are part of a closed system.

*On the discharge side of the thermocompressor, install straight pipe of at least the same or greater length than the diffuser. As the control valve (needle valve) can not shut off the steam, use a shut-off valve to shut off the equipment. (JC-MO, JC-AO)

• Operation

Confirm whether the control system's steam pressure or flow volume settings are correct, whether the air pressure of the positioner has been properly set and all other check items using the manufacturing specifications as well as the control valve instruction manual. (JC-AO)

1. Discharge the steam line's drain.
2. Open the valve's suction and discharge lines.
3. Slowly open the motive steam valve as far as it will go.
4. Confirm that the control system is functioning smoothly. (JC-AO)

Trial run: Measure motive pressure (P1), suction pressure (P2) and discharge pressure (P3) by means of pressure gages.

Any fluctuation in pressure change suction volume and discharge pressure as mentioned below:

1. In case motive pressure (P1) is much less than the specified value: [result]
Decrease in suction volume (Q2) and discharge pressure (P3)
2. In case suction pressure (P2) is much less than the specified value:
Decrease in suction volume (Q2) and discharge pressure (P3)
3. In case discharge pressure (P3) is far more than the specified value:
Decrease in suction volume (Q2)

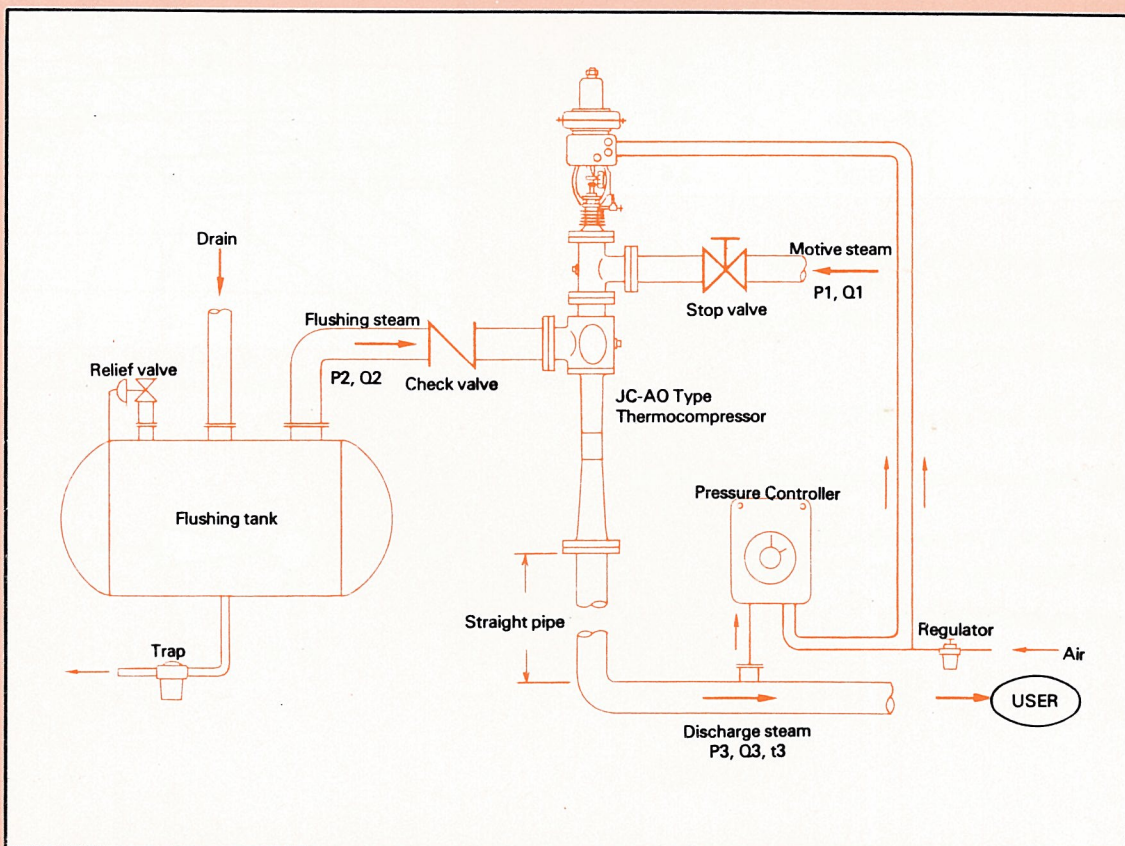

Results of Delivery (in Japan)

CHEMISTRY

MITSUBISHI CHEMICAL INDUSTRY LTD.
MITSUBISHI GAS CHEMICAL INDUSTRY LTD.
MITSUBISHI CEMENT INDUSTRY LTD.
MITSUI-TOATSU CHEMICAL INDUSTRY LTD.
MITSUI PETROCHEMICAL INDUSTRY LTD.
ASAHI CHEMICAL CO., LTD.
ASAHI GLASS CO., LTD.
CENTRAL GLASS CO., LTD.
NIHON PETROCHEMICAL INDUSTRY LTD.
NITTO CHEMICAL INDUSTRY LTD.
HODOGAYA CHEMICAL INDUSTRY LTD.
SEITETSU CHEMICAL INDUSTRY LTD.
DAISERU CHEMICAL INDUSTRY LTD.
NIHON-GOSEI CHEMICAL INDUSTRY LTD.
NIHON-SHOKUBAI CHEMICAL INDUSTRY LTD.
NIHON EP-RUBBER CO., LTD.
FUJI-PHOTO FILM CO., LTD.
NIHON-ZEON CO., LTD.
TOA-GOSEI CHEMICAL INDUSTRY LTD.
IDEMITSU PETROCHEMICAL INDUSTRY LTD.
NISSO-CHEMICAL INDUSTRY LTD.
MARUZEN PETROCHEMICAL INDUSTRY LTD.
KASHIMA-ISOPUREN CO., LTD.
SHOWA PETROCHEMICAL LTD.
KOA PETROCHEMICAL LTD.
SHIN-DAIKYOWA PETROCHEMICAL LTD.
KYOWA PETROCHEMICAL LTD.
FUJI PETROCHEMICAL LTD.
SUMITOMO CHEMICAL INDUSTRY LTD.
SHINETSU CHEMICAL INDUSTRY LTD.
OTSUKA CHEMICAL INDUSTRY LTD.
NISSAN CHEMICAL INDUSTRY LTD.
KANTO DENKA INDUSTRY LTD.
TOHO GAS CO., LTD.
TOKUYAMA SODA CO., LTD.
TOYO SODA CO., LTD.
YOKOHAMA RUBBER CO., LTD.
NIHON-GOSEI RUBBER CO., LTD.
BRIDGE-STONE TIRE CO., LTD.
OTSU TIRE CO., LTD.
SHOWA DENKO CO., LTD.
NIHON TABACCO SANGYO LTD.
SHIN-NIPPON STEEL WORKS LTD.

ENGINEERING

JAPAN GASOLINE CO., LTD.
ISHIKAWAJIMA-HARIMA HEAVY INDUSTRY
CO., LTD.
CHIYODA CHEMICAL ENGINEERING &

CONSTRUCTION CO., LTD.
MITSUBISHI CHEMICAL ENGINEERING CO., LTD.
ASAHI ENGINEERING CO., LTD.
NIIGATA ENGINEERING CO., LTD.
MARUZEN ENGINEERING CO., LTD.
MITSUI CONSTRUCTION CO., LTD.
TEIJIN CO., LTD.
UBE-KOSAN CO., LTD.
POWER REACTOR & NUCLEAR FUEL
DEVELOPMENT CORPORATION
MITSUBISHI HEAVY INDUSTRY LTD.
MITSUI SHIP-BUILDING & ENGINEERING LTD.
HITACHI SHIP-BUILDING & ENGINEERING LTD.
HITACHI PLANT CONSTRUCTION LTD.
MITSUI-MIIKE KAKOKI CO., LTD.
MITSUBISHI KAKOKI CO., LTD.
NICHIGO ENGINEERING CO., LTD.

PAPER PULP

OJI PAPER CO., LTD.
DAISHOWA PAPER CO., LTD.
JUJYO PAPER CO., LTD.
DAIO PAPER CO., LTD.
HONSHU PAPER CO., LTD.
KISHU PAPER CO., LTD.
NAGOYA PULP CO., LTD.
CHUETSU PULP CO., LTD.
TOYO PULP CO., LTD.
TAKASAKI PAPER CO., LTD.
GOJYO PAPER CO., LTD.

FOOD

YUKIJIRUSHI-MILK INDUSTRY LTD.
SUNTORY LTD.
SANRAKU-OCEAN LTD.
OJI CORNSTARCH LTD.
KYOWA-HAKKO INDUSTRY LTD.
RINORU OIL CO., LTD.
AJINOMOTO CO., INC.
NANSEI SUGAR INDUSTRY LTD.

Manufacturing Specifications

When asking for an estimate or placing an order, please be sure to specify the following data:

JC			
Motive steam pressure	P1	kg/cm ² G	°C
Suction pressure	P2	kg/cm ² G	°C
Discharge pressure	P3	kg/cm ² G	°C
Motive steam volume	Q1	kg/H	
Suction steam volume	Q2	kg/H	
Discharge volume	Q3	kg/H	
Materials	Body • Nozzle Diffuser		
Flange standards	ANSI () • JIS ()		
Please specify Q1, Q2 or Q3.			

JC-MO/JC-AO			
Motive steam pressure	P1	kg/cm ² G	°C
Suction pressure	P2	kg/cm ² G	°C
Discharge pressure	P3	Constant	kg/cm ² G
		Fluctuation ~	kg/cm ² G
Motive steam volume	Q1	kg/H	
Suction steam volume	Q2	kg/H	
Discharge volume	Q3	Constant	kg/H
		Fluctuation ~	kg/H
Material	Body • Nozzle Diffuser		
Flange standards	ANSI () • JIS ()		
Please specify Q1, Q2 or Q3.			

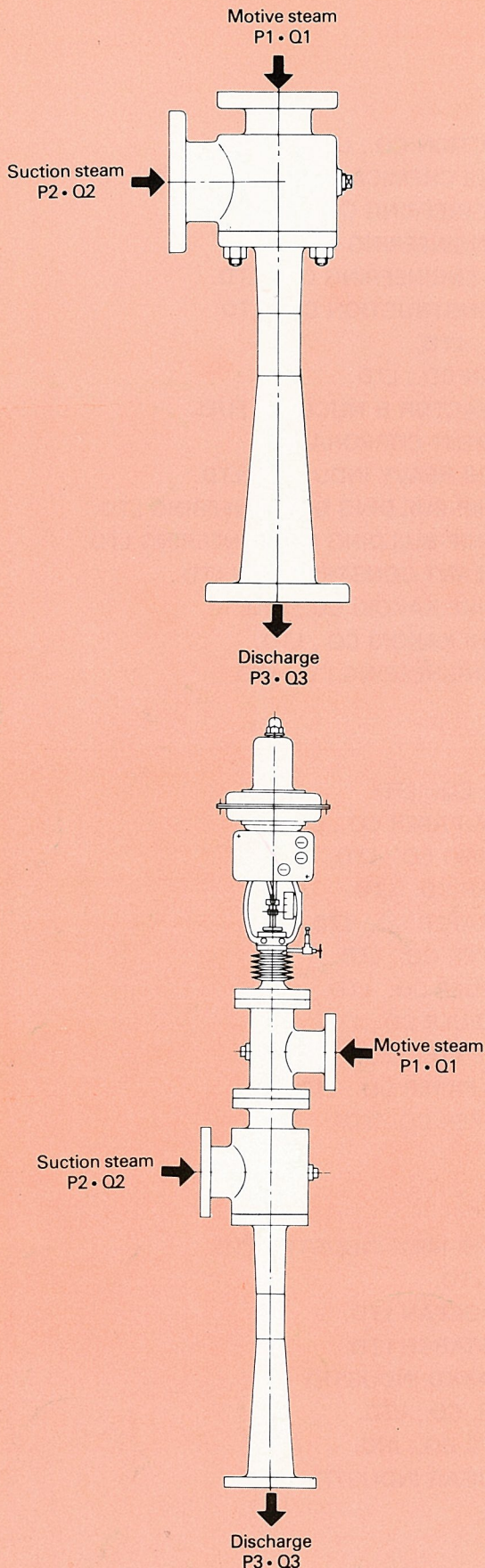

Manufacturer

HOKUTO MFG. CO. LTD.

HEAD OFFICE: 3-23-27-101, Higashi-Shinagawa

Shinagawa-ku, Tokyo, 140, JAPAN

TEL : 03-471-5021 FAX : 03-471-5024

TWX, FAX : 81-3-471-5024

Authorized representative